

Designed to

- Replicate Anatomic Joint Surfaces
- Preserve Bone
- Minimize Disruption to the Collateral Ligaments



SR™ PIP
IMPLANT SYSTEM



SR™ MCP
IMPLANT SYSTEM

SR™ MCP and SR™ PIP Finger Prosthesis Benefits

- > **Pain Relief** - Recent (2001) studies have concluded that the anatomic designs of the SR™ family of finger implants can provide pain relief and restore joint kinematics for patients requiring finger joint arthroplasty.
- > **Extended Range of Motion** - By anatomically replacing joint surfaces and retaining critical soft-tissue structures, range of motion and function may be restored without artificial constraints or damage to ligaments or tendons.
- > **Stable, Long Lasting** - The congruent semi-constrained articular surfaces minimize stress concentrations and related complications, translating to stable, longer lasting implants that can withstand the demands of everyday hand functions.
- > **Proven Materials** - These unique two-piece designs utilize the same proven biocompatible materials found in hip and knee replacements: Cobalt Chrome, Titanium Alloy and UHMWPe.
- > **Anatomic Sizing** - Each implant is available in multiple sizes to address varied patient anatomy.
- > **Complete Instrumentation** - Implant specific instrumentation optimizes surgical precision. Instruments include awls, rasps, sizers, inserters and extractors.

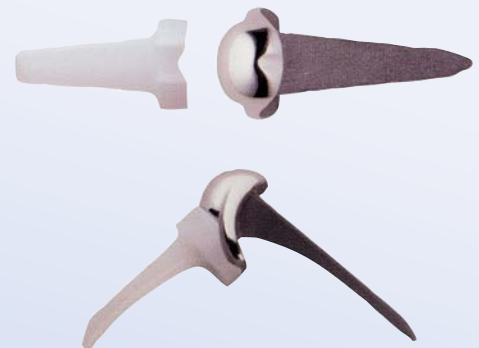

The SR™ MCP Finger Prosthesis



The SR™ PIP Finger Prosthesis

HUMANITARIAN USE DEVICES

The SR™ PIP and MCP prostheses are available in the United States in Humanitarian Use Devices. Contact Small Bone Innovations for additional information. Additional details can be found at our website: www.totalsmallbone.com

US FDA regulations restrict the sale of this device to or on the order of a physician.

For further information please see Instructions for Use and Surgical Technique.

SR™ MCP and SR™ PIP Instrument Trays

- Each set of MCP and PIP instruments contains color coded broaches and matching color coded trial sizers for fast and accurate identification.
- The MCP instrument set contains a metacarpal and phalangeal broach for each of the seven implant sizes, one starter awl, one double-ended rasp and one sizer for each implant size.
- The PIP instrument set contains a proximal and middle phalangeal broach for each of the five implant sizes, one starter awl, one double-ended rasp and one sizer for each implant size.



The Surface Placement Prosthetic Design Was Based on the Premises That

- A semi-constrained finger prosthesis may give a more physiologic articulation than a constrained prosthesis.
- A properly centered anatomical configuration may more reliably restore tendon moments to the joint.
- Minimal bony excision and preservation of the collateral ligaments may provide a more stable joint particularly to imposed lateral forces.
- Preservation of the capsule may allow diversion of some of the transverse forces and dazial torques from the prosthesis endoseal interface to the lateral cortices throught the collateral ligaments.
- A more physiologic force distribution may diminish the mechanical contribution to osteolysis and subsidence at the bone prosthesis interface.

SR™ PIP and SR™ MCP Implant Dimensions

SR™ PIP Dimensions

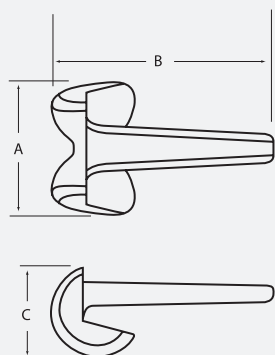

PROXIMAL COMPONENT
dimensions (mm)

SIZE	A	B	C
1	7.7	15.9	5.7
2	8.7	18.1	6.5
3	9.9	20.6	7.4
4	11.1	23.1	8.3
5	12.4	25.8	9.3

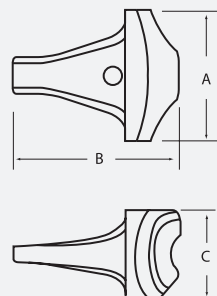

DISTAL COMPONENT
dimensions (mm)

SIZE	A	B	C
1	7.8	11.0	5.0
2	8.9	12.5	5.7
3	10.1	14.3	6.5
4	11.3	16.0	7.3
5	12.7	17.9	8.2

SR™ MCP Dimensions

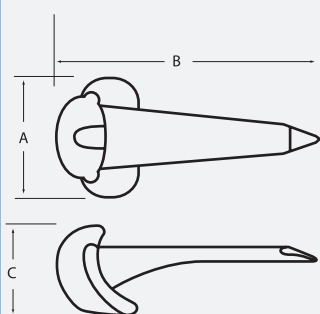

PROXIMAL COMPONENT
dimensions (mm)

SIZE	A	B	C
XS	10.9	24.1	7.3
S	12.3	27.1	8.4
M	13.6	30.1	9.4
L	15.0	33.2	10.4
XL	16.4	36.2	11.4

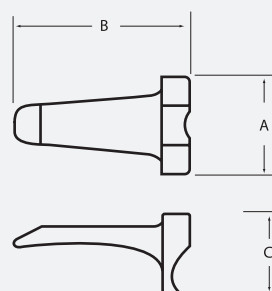

DISTAL COMPONENT
dimensions (mm)

SIZE	A	B	C
XS	9.1	17.0	7.7
S	10.2	19.1	8.7
M	11.3	21.1	9.6
L	12.4	23.1	10.6
XL	13.6	25.1	11.6

SMALL BONE INNOVATIONS

Small Bone Innovations, Inc.
1380 South Pennsylvania Avenue
Morrisville, PA 19067
(215) 428-1791 / Fax (215) 428-1795
SBI Customer Service: (800) 778-8837
Technical Support: (866) SBI-TIPS
www.totalsmallbone.com
customerservice@totalsmallbone.com

Small Bone Innovations International
ZA Les Bruyères - BP 28
01960 Péronnas, France
Tel: +33 (0) 474 21 58 19
Fax: +33 (0) 474 21 43 12
info@sbi-intl.com